



Transferline Microwave
Engineer's RF Partner

TL6000 Large Dynamic Range OTDR

Datasheet



Product Overview

The TL6000 OTDR can be used to test single-mode wavelengths of 1310nm, 1550nm, 1490nm, 1625nm and 1650nm, multi-mode wavelengths of 850nm and 1300nm as well as customized special wavelengths. It provides multiple optional modules, such as single wavelength, multi-wavelength and online test. With the maximum dynamic range of up to 50dB, the device can be used for remote multi-branch communication network test. It's designed with a minimum event dead zone of 0.5m which makes the near connection easy to be supervised, and the lowest sampling resolution of 2.5cm which enables it to locate the event point accurately. Additionally, the device is also designed with multiple convenient functional options, such as stable light source, optical power meter, visible red light source and fiber end face inspection tester.

TL6000 OTDR is designed with an operating temperature and a storage temperature of $-10^{\circ}\text{C}\sim 50^{\circ}\text{C}$ and $-40^{\circ}\text{C}\sim 70^{\circ}\text{C}$ respectively to meet both EMC requirements as well as vibration and shock test requirements, a MTBF(θ) of 6000h or above to ensure a high reliability, and a 75W built-in Li battery to ensure an endurance for continuous measurement in the wild field.

Main Characteristics

- A maximum dynamic range of 50dB, and 256k data sampling points
- Online test of PON network
- Integrated single-mode and multi-mode test
- Automatic monitoring of optical communication signals
- File formats of Bellcore GR196 and SR-4731 supported



Rapid automatic test

Due to the automatic test function of TL6000, it's not necessary for the user to know more about its operation. Connect the optical fiber and press the [Test] button. Then, the device will set the optimum test conditions automatically, and finally output accurate test results, such as the test curve and the list of events.

Unique PON network test

As an ideal tester of ODN and FTTx, TL6000 is provided a unique built-in PON network test function, can penetrate an optical splitter of up to 1:128, and can be used to test each branch of the PON network accurately.

Automatic monitoring and alarm of incoming optical signals

When the OTDR is testing the optical fiber line, the optical communication signal in the optical fiber, if any, will lead to inaccurate test results and even unrecoverable damages to the detectors in the device. TL6000 can monitor the optical communication signal in the optical fiber under test automatically. As long as the optical fiber under test is connected to the optical interface of TL6000, the device can automatically sense and monitor whether there is optical communication signal in it. Once an optical signal is monitored, it will prompt an alarm in time, so as to provide the quickest and the most timely protection for the device.

Typical Applications

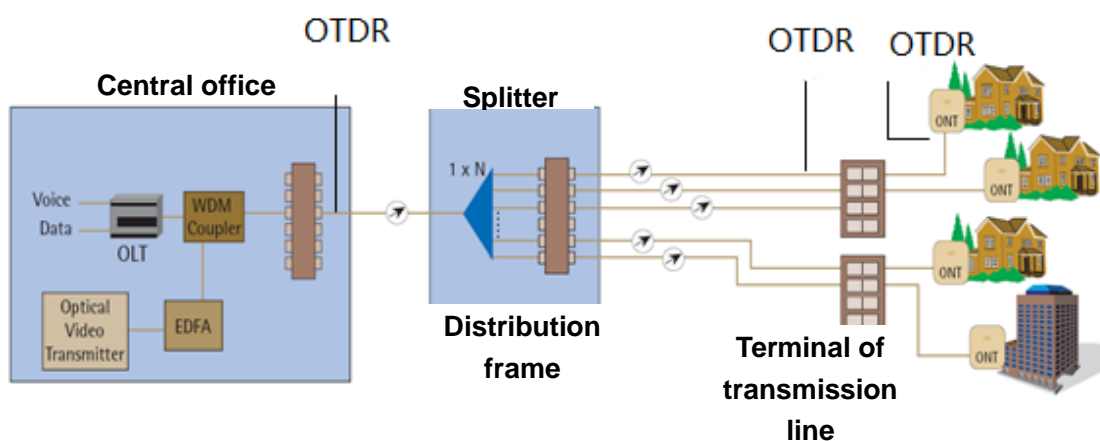

Technical Specifications

Maximum dynamic range	See the “ Technical specifications for each standard module of TL6000 OTDR ” for more information.
Ranging accuracy	$\pm(0.75 + \text{sample interval} + 0.0025\% \times \text{range})$ (excluding the refractivity placement error) (m)
Ranging resolution	0.05, 0.1, 0.2, 0.5, 1, 2, 4, 8, 16 and 32m
Test range	0.4, 0.8, 1.6, 3.2, 6.4, 16, 32, 64, 128, 256 and 512km (single-mode); 0.4, 0.8, 1.6, 3.2, 6.4, 16 and 32km (850nm multi-mode)
Testing PW	3, 5, 10, 30, 80, 160, 320, 640, 1280, 5120, 10240 and 20480ns 3, 5, 10, 30, 80, 160, 320, 640 and 1280ns(850nm multi-mode)
Maximum number of sampling points	256k
Linearity	0.03dB/dB
Loss resolution	0.001dB
Refractivity setting range	1.00000 ~ 1.99999(step: 0.00001)
Range unit	km, m, thousand feet, feet
Display	800×480, 7-inch TFT color LCD (a capacitive touch screen in the standard configuration, and a resistive touch screen optional)
Optical output interface	FC/UPC (standard configuration, with LC/UPC, SC/UPC and ST/UPC optional)
Interface language	Simplified Chinese, English, Russian and Korean available (contact the office for other language support)
External interfaces	USB, Micro-USB, 10M/100M Ethernet, earphone and Micro SD
Power supply	AC/DC adapter: AC100V~240V, 50/60Hz and 1.5A DC: 17V±3V(2A) Internal Li battery: 11.1V, 6800mAh, battery operating time: 8h
Maximum power consumption	10W
Dimensions	252mm(W)×180mm (H)×55mm (D)
Weight	About 1.8kg
Environmental adaptability	Operating temperature: -10°C~+50°C (battery charging: 5°C~40°C) Storage temperature: -40°C~+70°C (battery: -20°C~60°C) RH: 5% ~95%, no condensation

- VFL (optional)

- Operating wavelength: $650\text{nm} \pm 20\text{nm}$

- Output power: 2mW (typical)

- Operating mode: CW, 1Hz and 2Hz

- Optical power meter (optional)

- Wavelength range: 850nm~1650nm

- Power range: -60dBm~+3dBm

- Uncertainty: $\pm 5\%$ (-25dBm, CW)

- Stable light source (optional)

- Operating wavelength: the same as OTDR

- Output power: $\geq -5\text{dBm}$

- Operating mode: CW, 270Hz, 1kHz and 2kHz

Technical specifications for each standard module of TL6000

OTDR¹

Module number	Operating wavelength	Laser wave length	Dynamic range ² (dB)	Event dead zone ³ (m)	ATT dead zone ⁴ (m)
TL6000-1105	Single-mode 1625nm (built-in filter)	Single-wavelength	36	0.8	3
TL6000-1106	Single-mode 1650nm (built-in filter)		36		
TL6000-1201	Multi-mode 850nm		24	1	5
TL6000-1202	Multi-mode 1300nm		36		
TL6000-2101	Single-mode 1310/1550nm	Dual-wavelength	37 / 35	0.5	3
TL6000-2102	Single-mode 1310/1550nm		42 / 40		
TL6000-2103	Single-mode 1310/1550nm		45 / 42		
TL6000-2105	Single-mode 1550/1625nm (built-in filter)		36 / 36		
TL6000-2107	Single-mode 1550 /1650nm (built-in filter)		36 / 36		
TL6000-2109	Single-mode 1310 /1550nm		46 / 46		
TL6000-2108	Single-mode 1310/1550nm		30 / 28		
TL6000-2201	Multi-mode 850nm/1300nm		26/34	0.7	5
TL6000-3101	Single-mode 1310/1490/1550nm		Three-wavelength	37/35/35	0.5
TL6000-3102	Single-mode 1310/1550/1625nm(built-in filter)	37/35/35			
TL6000-3103	Single-mode 1310/1550/1625nm(built-in filter)	42/40/40			
TL6000-3104	Single-mode 1310/1550 /1650 nm(built-in filter)	42/40/40			
TL6000-3105	Single-mode 1310/1550/1650nm(built-in filter)	37/35/35			
TL6000-3106	Single-mode 1310/1550/1625nm(built-in filter)	30/28/28			
TL6000-4101	Single-mode 1310/1490/1550/1625nm(built-in filter)	Four-wavelength	37/35/35/35	0.5	3
TL6000-4105	Single-mode 1310/1490/1550/1650nm(built-in filter)		37/35/35/35		
TL6000-4001	Single-mode 1310/1550nm, multi-mode 850/1300nm		37/35/26/34	0.7	5
TL6000-4002	Single-mode 1310/1550nm, multi-mode 850/1300nm	Four-wavelength	30/28/24/28	0.7	5

Notes: 1. One must and only one can be chosen for the standard module.

2. An ambient temperature of 23°C±5°C, the maximum test PW, over 500 times averagely, and a SNR of 1.

3. A range of 1.6km or smaller, a PW of 3ns, a fiber end face reflection loss of 40dB or above, and a typical value.
4. A range of 1.6km or smaller, a PW of 5ns or smaller, a fiber end face reflection loss of 50dB or above, and a typical value.

Order Information

● Main unit:: **TL6000 OTDR**

● Standard configuration:

S/N	Description	Remarks
1	Power line assembly	Power line and power adapter: an input voltage of 100~240V, 50~60Hz, an output voltage and an output current of 19V and 3.42A respectively at 2.0A
2	User manual	-
3	Product certificate of conformity	-
4	CD	Including simulation analysis software
5	Special portable soft bag of OTDR	-
6	Special strap of OTDR	-

● Options:

	Description	Function
TL6000-001	USB	USB
TL6000-002	SD card	SD card
TL6000-003	USB data cable	USB data cable
TL6000-004	Spare battery pack	6417LB-1192
TL6000-005	LC, SC and ST adapters	LC, SC and ST adaption
TL6000-006	Single-mode optical fiber adaption jumper	FC/UPC adapted to FC/APC
TL6000-007	Single-mode optical fiber adaption jumper	FC/UPC adapted to SC/UPC
TL6000-008	Single-mode optical fiber adaption jumper	FC/UPC adapted to LC/UPC
TL6000-009	Special engineering plastic case of OTDR	Special engineering plastic case (including the strap)

● Packing case:

Special soft bag



Special engineering plastic case(option)

● Information for choosing:

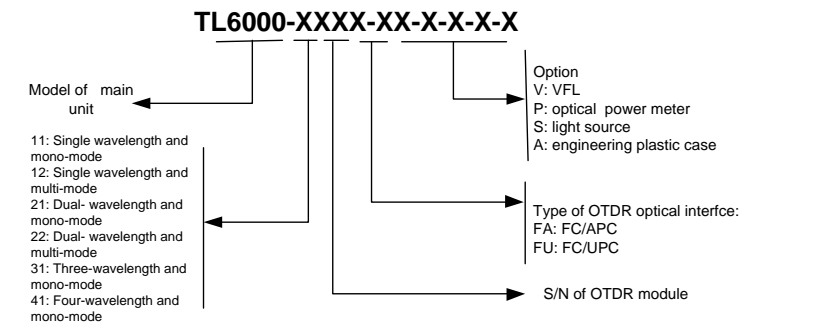

Note: Due to the design improvement requirement, the contents mentioned above can be modified without notice.